

INSTALLATION, OPERATION AND MAINTENANCE INSTRUCTIONS

Protecta III - GRP (LED) Emergency Luminaire

ATEX & IECEX

Important: Please read the following instructions carefully prior to installation or maintenance of this equipment.

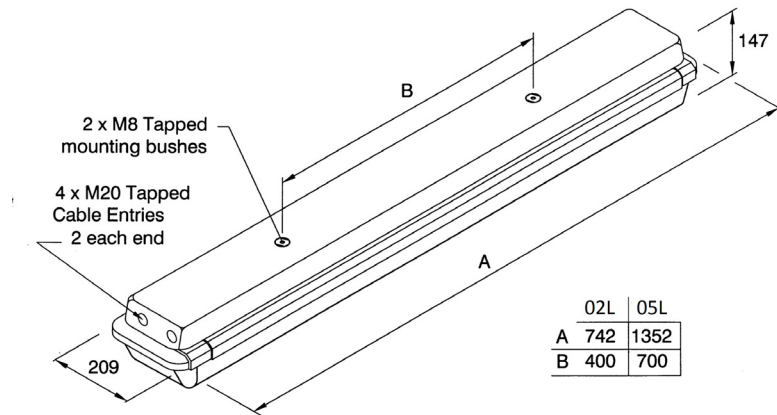



Type Of Protection	LED std. with d switch or LTT option or LT option	Ex e mb q (Increased safety, Encapsulation, Powder filing), Ex tb (dust). Ex d e mb q Ex d e mb q Ex e mb q
Protection Standards	(IEC) EN 60079-0, (IEC) EN 60079-1, (IEC) EN 60079-5, ((IEC) EN 60079-7, (IEC) EN 60079-18, (IEC) EN 60079-28, (IEC) EN 61241-1	
Area Classification	Zone 1 and Zone 2 areas to (IEC) EN 60079-10-1 Zone 21 and Zone 22 areas to (IEC) EN 60079-10-2	
Installation	(IEC) EN 60079-14	
Certificate	IECEX Certificate of Conformity IECEX BAS 09.0017 EU- Type Examination Certificate Baseefa04ATEX0220	
Equipment Coding	Ex e mb op is q IIC T4 Gb or Ex d e mb op is q IIC T4 Gb Ex mb op is tb IIIC T95°C Db IP6X -25°C ≤ Ta ≤ +55°C or -40°C ≤ Ta ≤ +45°C LTT option (fitted with heater and thermostat). or -40°C ≤ Ta ≤ +55°C LT option (fitted with heater). Ex db e mb op is q IIC T4 Gb (fitted with Hawke CSPU stopping plug)	
ATEX Coding	⊕ II 2GD	
Ingress Protection	IP66/67 to EN(IEC) 60529	
CE Mark	 <p>The CE marking of this product applies to "The Electrical Equipment (Safety) Regulations 2006", "The Electromagnetic Compatibility Regulations 2004", the "Waste Electrical and Electronic Equipment Regulations 2006" and the "Equipment and Protective Systems intended for use in Explosive Atmospheres Regulations 1996". [This legislation is the equivalent in UK law of EU directives 2014/35/EU, 2014/30/EU, 2012/19/EU and 2014/34/EU respectively].</p> <p>The Equipment is declared to meet the provisions of the ATEX directive (2014/34/EU) by reason of the EU Type Examination and compliance with the Essential Health and Safety Requirements. M Poutney Technical Manager</p>	

1.0 Introduction – Protecta LED GRP ATEX and IECEX

This installation leaflet covers the range of ATEX and IECEX Protecta GRP LED Emergency luminaire models with the Ex q control gear. These luminaires are mainly used in harsh environments and are constructed using a corrosion resistant glass reinforced polyester body and polycarbonate diffuser. The integrated unit consists of a battery pack and a mains supplied driver to supply the LED strips and charge the battery pack in normal situations and power the LED strips from the battery pack in an emergency situation. The driver monitors the emergency functions and displays the emergency unit status by means of a green LED. Refer to the current catalogue for information on product references. The luminaires are available in 02L (2ft) and 05L (4ft) sizes.

2.0 Electrical Supplies

Lamps	02L - 2 x 600mm LED Strip	05L - 2 x 1200mm LED Strip
Voltage range AC	110-130V or 220-254V	
Frequency range Hz	47-63Hz	
Power Watts 220-254V	34W	64W
Current Amps 220-254V	0.17 – 0.15A	0.30 – 0.26A
Power Watts 110-130V	34W	64W
Current Amps 110-130V	0.34 - 0.28A	0.61 - 0.51A

The safety limit for surface temperature (T rating) is +/-10% on the rated voltage. The maximum nominal variation from rated voltages stated above is +/- 6%.

Batteries	6V 4Ah NiCd (02L) 6V 7Ah NiCd (05L)
Emergency Duration	90 minutes or 3 hours depending on model specified
Power Factor >0.95	Power is constant over voltage range.
Over Voltage	400V ac for 1 min



Through Wiring

The through current rating is 16A. 4mm² terminals are standard (6mm² wiring can be used in the terminals in accordance with the luminaire certificate).

Fuse and MCB Ratings

It is recommended that for selection of MCBs users should consult the MCB manufacturer as this unit contains electronic control gear. The electronic control gear has nominal values of inrush current of 35A for 70µs on 230V and 70A for 70µs on 110V.

Storage

Luminaires are to be stored in cool dry conditions preventing ingress of moisture and condensation. Storage temperature range to be -40°C to +80°C.

Battery packs in storage should be cycled charged/discharged/charged every 9 months, as per instructions below.

Always disconnect battery plug and socket for storage.

Any specific instructions concerning emergency luminaires must be complied with.

(Warning: Battery packs not cycled and stored for a year may not be recoverable)

Typical wiring diagram shown for information only, some models may differ.

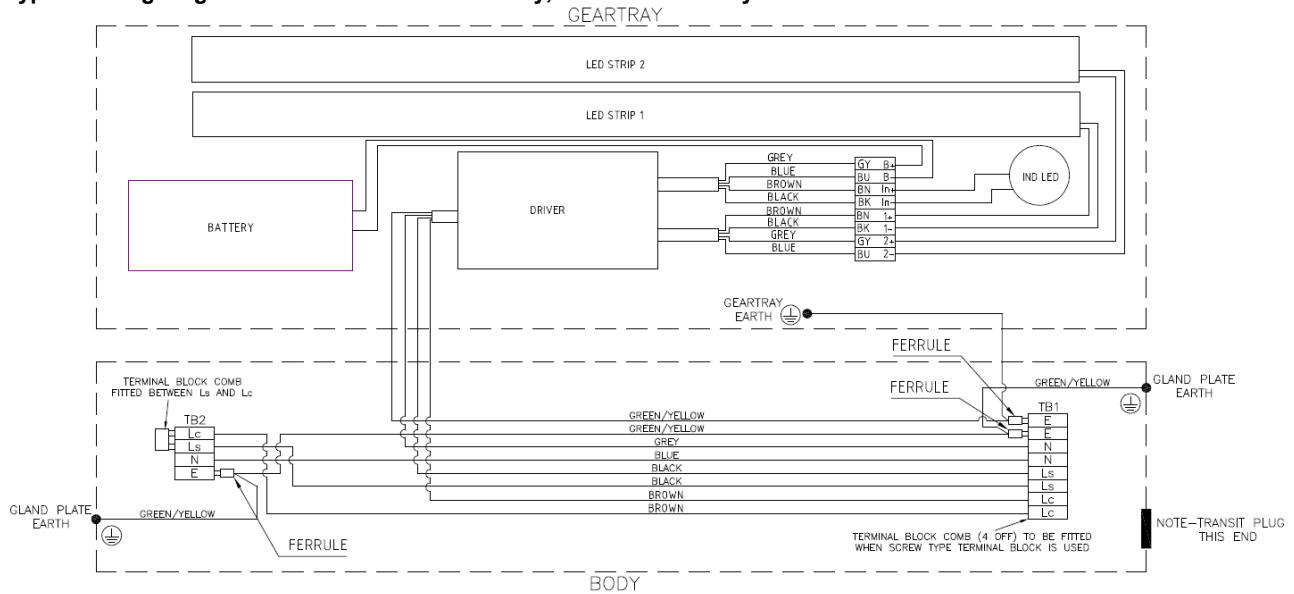

3.1 General

These instructions should be read fully and carefully before attempting to install the luminaire. For details of servicing operations, opening etc. see section 4.0.

Copies of these instructions should be held in a safe place for future reference. It is the responsibility of the installer to ensure that the apparatus selected is fit for its intended purpose and that the installation, operation and maintenance of the apparatus complies with applicable regulations, standards or codes of practice. Installation should be carried out in accordance with (IEC) EN 60079-14 or with a local hazardous area code of practice, whichever is appropriate.

Risk of electrostatic discharge:

- Clean diffuser only with damp cloth
- Avoid mounting near fast moving streams of air

Any specific installation instructions must be referred to. In the UK the requirements of the *Health and Safety at Work Act* must be met and electrical work associated with this product must be in accordance with the *"Manual Handling Operations Regulations"* and *"Electricity at Works Regulations 1989"*. Disposal instructions should be complied with. The luminaires should be considered Class 1 to EN 60598 and effectively earthed. Certification details on the rating plate must be verified against the application requirements before installation. The information in this leaflet is correct at the time of publication. The company reserves the right to make specification changes as required without notice.

Luminaires are shipped with the battery pack **disconnected**, connection must be made on initial installation. **See 5.8.**



3.1.1 Use in Combustible Dust Atmospheres

- De-rating of the surface temperature will be required where dust clouds may be present
- Do not allow dust to accumulate in layers
- Dust in layers has the potential to form ignitable clouds and to burn at lower temperatures

Refer to EN (IEC) 60079-10-2 & EN (IEC) 60079-14 for additional details of selection and installation.

3.2 Tools

3mm and 4mm flat blade screwdriver and large crosshead screwdriver. Suitable spanners for installing cable glands. Pliers, knife, wire strippers/cutters.

3.3 Mounting

Luminaires should be installed where access for maintenance is practical and in accordance with lighting design information. For horizontal mounting on handrails Chalmit recommend mounting the luminaire with the clamp bar uppermost therefore allowing the diffuser and gear tray to swing down when necessary. Refer to the note in 3.1 concerning electrostatic charge. The standard suspension is via two M8 x 12mm deep blind tapped holes in stainless steel bushes in the top of the body, the recommended torque for the fixing bolts is 10-15Nm. Various adaptors, pole clamps and suspension brackets are available to order.

3.4 Cabling and Cable Glands

The temperature conditions at the supply cable entry point are such that 70°C (ordinary PVC) cable can be used. Equipment certified cable glands and sealing plugs must have suitable IECEx/ATEX approval. When installed the cable gland or sealing plug should maintain the IP rating of the enclosure, IP66/67.

Four entries are provided. Three entries are fitted with suitably approved blanking plugs, the fourth entry with a transit plug. M20 x 1.5 entries are standard, other sizes are available on request. The standard entry configuration is with an earthed metal plate with tapped holes mounted in the body.

3.5 Electrical Connections and Testing

If any work is to be done on any luminaire already connected to the electrical system, the luminaire must be isolated from the system. The diffuser cover is swung down and removed, if necessary, by swivelling back as far as possible then lifting off. To access the mains terminals loosen the four fixing screws, slide the reflector/gear tray over the slots and swing the reflector/gear tray down. Luminaires are supplied suitable for looping and through wiring. Screw type or screw-less "cage clamp" terminals are fitted in the range of luminaires. Mains terminal blocks are marked L N Earth.

Mains terminal blocks on the emergency luminaires are marked Lc Ls N Earth.

Switching the voltage on the Ls connection enables the luminaire to be switched on and off without the emergency function being activated. The Ls connection is insulated from L and has a signal function only drawing a very small current.

The emergency units can be connected as switched, un-switched or non-maintained units. The switching facility is to allow the luminaire to be switched off whilst still charging the battery. Where switching is required, the un-switched line (Lc) is connected to the continuous mains supply. A link is fitted during assembly between Lc and switched line (Ls); this is removed for the switch-able mode. If the link is removed and Ls not supplied, the unit will only operate on emergency.

The maximum amount of insulation allowed beyond the throat of the terminal is 1mm. The normal method of insulation testing is to connect Live and Neutral together and test between this point and Earth to prevent the risk of damage to the electronic control gear. However, if this is not possible luminaires can be tested with an insulation tester that complies with IEC 364 or BS 7671 with a maximum output current of 1mA and output voltage of 500V dc. (Units damaged by incorrect insulation testing can be detected). Before completing the wiring, ensure that all the connections are correctly introduced into place before reassembling the luminaire.

4.0 Emergency Operation

4.1 General description of operation

The luminaire will go seamlessly into emergency mode at not less than 60% rated supply voltage and will remain in mains mode above 85% of rated supply voltage.

The charging function is monitored continuously, there is a check for over charging and no charging. In case of a control gear error, the indicator will flash quickly on and off. Batteries will fully charge within 24hrs.

After a complete battery discharge, the unit will switch over to a low discharge current mode.

LED display

The status is displayed by means of green LED signals.

The LED will flash slowly, if the batteries are being charged.

The LED will be steady at full charge.

The LED will flash quickly if there is a fault or a warning.

The LED will be off during emergency operation.



4.2 Low Temperature Operation

At battery temperatures below 10°C charge time can increase. This temperature is equivalent to the luminaire operating at -5°C with the LEDs on or at +5°C with the LEDs off.

Under operating conditions where the ambient temperature is below 0°C for long periods the luminaire should be purchased with Low Temperature option. This incorporates a heater to maintain the batteries at a sufficient temperature.

5.0 Servicing and Operation

Safe servicing behind the gear tray requires the mains supply to be isolated.

5.1 Opening and Closing the Cover

Insert a screwdriver into one of the slots in the clamping bar with the end of the tool located into the outer flange of the body as a fulcrum point, a wide blade screwdriver is recommended. Gently lever the tool away from the diffuser, the clamping bar will begin to open. Insert the tool in the other clamping bar slot and gently lever away from the diffuser, the clamping bar will open and the cover will be retained by the hinge. Should difficulty be experienced reinsert the tool in the first slot and repeat the procedure.

The procedure for closing and securing the cover is as follows:

Ensure the hinge mechanism is clear of any obstruction and then swing the diffuser into the closed position. Support the diffuser in position whilst pushing the clamp bar over the edge of the diffuser. Apply even pressure at both ends of the bar and press the bar over centre making sure that it goes fully into position.

To remove and replace the diffuser open the diffuser to 180° and it will lift out. When replacing ensure that all the hinges are into place before attempting to close.

5.2 Removal and Replacement of Clamping Bar (if required)

Open the luminaire as above and remove the diffuser or let it swing down. Press the clamping bar towards the closed position, tip forward beyond the closed position and the clamping bar will be released from the body. To replace the clamping bar, put in position on the body with the front edge pointing as far inwards as it will go. Click the bar outwards and bring back to the normal closed position. The clamping bar should then be secured in position, open the clamping bar fully by using hand or screwdriver pressure (avoid damaging the gasket), the clamping bar is then ready to accept the normal closure of the diffuser.

5.3 Servicing Behind the Gear Tray

The release of the gear tray exposes live mains terminals. Any work behind the gear tray requires that the supply is isolated to avoid ignition risk and damage to components.

5.4 Releasing the Gear Tray

Loosen the four fixing screws retaining the gear tray far enough for it to slide over keyhole slots. The tray will hang on the retaining cords without stressing the wiring between body and tray. Replace in reverse order.

5.5 Removal of Gear Tray

Release gear tray from body and hang on retaining cords, as explained above. Disconnect the cables from the gear tray to the mains terminal block, unhook retaining cord from gear tray and lift clear. With disconnection made at the screw-less terminals the luminaire is safe when re-closed without the tray.

5.6 Replacement of LED Strips

Remove gear tray from the body and swing down as previously explained. Identify the wires for the LED strip/s and disconnect from the terminal block. Remove screws and clips holding the strips in place. Replace strips using screws and clips and reconnect to terminal block. Check connections before re-energising.

5.7 Replacement of Driver

The driver contains no serviceable parts. Should it be found necessary to replace the driver, the following procedure should be adopted: Ensure that the luminaire is isolated from the mains supply.

Remove gear tray from body and swing down as previously explained. Disconnect the driver wires from the terminal blocks (note the connections) and remove the driver from the tray.



5.8 Replacement of Battery

Replacement/ connection of Battery can only take place when there is NO Explosive gas or dust atmosphere present.

05L: The battery is connected to the control using a plug and socket arrangement. The screws holding the battery pack are loosened and the battery pack slid axially one way then the other in order to release. Upon replacement of the battery pack remember to tighten the screws.

02L: The battery is supplied complete with bracket and terminal connections. When removing battery pack, disconnect wires coming from driver to battery terminal connections (wires from battery pack must stay connected to the terminal block) and remove battery assembly. Replace in reverse.

Additional wiring connections are required if the heater assembly is fitted. Consult wiring diagram supplied with replacement battery pack for details.

The battery packs are not intended to be opened and are replaced as a unit. **The battery assembly must be protected from damage and water ingress then removed from any potentially hazardous area as soon as practical.**

The luminaire must not be operated without the battery connected. If the battery is removed and not replaced, the control gear supply must be disconnected at the mains terminal block and secured.

5.9 Checking of Battery separately

If the battery is to be checked separately, it should be charged using a **constant current charger** at 200/400mA for 30/15 hours for the 4Ah or 350/700mA for 30/15 hours for the 7Ah. Discharge measurement is not easy as the current is proportional to the voltage for resistance loads, so it has to be averaged. Discharge the battery at 1 to 2A and multiply current by time. Do not discharge below 1 volt per cell, which is 5V. The capacity should be 75% or more of normal.

6.0 Routine Maintenance

Visual tests and checks should be carried out at intervals described by the appropriate regulations, EN 60079-17, and should include the following:

- Check for mechanical damage/corrosion.
- Check connections, fixings, glands and plugs.
- Check for undue accumulations of dust, dirt or moisture.
- Check for unauthorised modifications.

Periodic inspection of the enclosure seal should be carried out to ensure that the seal is sound. If the luminaire has been subject to abnormal conditions, for example, severe mechanical impact or chemical spillage, it must be de-energised until it has been inspected by an authorised and competent person

6.1 Cleaning

The body of the luminaire may be cleaned with a mild solution of household detergent and water, after cleaning the body should be washed and wiped with clean water. **The diffuser should not be polished or wiped with a dry cloth as a risk of ignition due to electrostatic discharge may result.** Cleaning of the diffuser with any chemical or hydrocarbon solvent based cleaner may result in severe damage.

7.0 Disposal of Material

General

Disposal of the luminaire as waste should be carried out in accordance with national regulations. Any disposal must satisfy the requirements of the [WEEE directive \[2012/19/EU\]](#) and therefore must not be treated as commercial waste. The unit is mainly made from incombustible materials. The control gear contains plastic, resin and electronic components. All electrical components may give off noxious fumes if incinerated.

7.1 Battery Disposal

Nickel cadmium batteries are defined as 'controlled waste' under the hazardous waste regulations and the person disposing needs to observe a 'duty of care'.

Batteries can be returned to the manufacturers for recycling. They must be stored and transported safely and any necessary pollution control forms completed prior to transportation. Take care to fully discharge batteries before transporting, or otherwise ensure that there can be no release of stored energy in transit. For further details refer to our Technical Department.

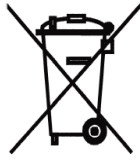

To comply with the Waste Electrical and Electronic Equipment directive 2012/19/EU the apparatus cannot be classified as commercial waste and as such must be disposed of or recycled in such a manner as to reduce the environmental impact.

Chalmit Lighting is a leading supplier of Hazardous Area lighting products

	<p>CHALMIT LIGHTING PO Box 5575 Glasgow, G52 9AP Scotland</p>	
<p>Telephone: +44 (0) 141 882 5555 Fax: +44 (0) 141 883 3704 Email: info@chalmit.com Web: www.chalmit.com</p>	<p>Registered No: 669157 Registered Office: Cannon Place 78 Cannon Street London EC4N 6AF UK</p>	

For technical support, please contact: techsupport@chalmit.com

Note: Chalmit Lighting reserves the right to amend characteristics of our products and all data is for guidance only.



	EU-Declaration of conformity		
	UE-Déclaration de conformité		
	EU-Konformitätserklärung		
Manufacturer	Chalmit	Address	388 Hillington Road, Glasgow. G52 4BL Scotland UK
Product	Protecta III GRP (LED) Emergency Luminaire.		
EU - Type Examination Certificate	Baseefa04ATEX0220		
Notified Body	SGS KFimko OY 0598		
ATEX Coding	II 2 GD	ATEX Classification	Group II Category 2 GD
Equipment Coding	Ex e mb op is q IIC T4 Gb or Ex d e mb op is q IIC T4 Gb Ex mb op is tb IIIC T95°C Db IP6X -25°C ≤ Ta ≤ +55°C or -40°C ≤ Ta ≤ +45°C LTT option (fitted with heater and thermostat). or -40°C ≤ Ta ≤ +55°C LT option (fitted with heater). Ex db e mb op is q IIC T4 Gb (fitted with Hawke CSPU stopping plug)		
Ingress Protection	IP66/67		
The technical basis, with respect to equivalence of			
La base technique, en ce qui concerne l'équivalence de			
Die technische Grundlage hinsichtlich der Normen			
Protection Standards EN 60079-0, EN 60079-1, EN 60079-5, EN 60079-7, EN 60079-18, EN 60079-28, EN 61241-1			
Area Classification EN 60079-10-1 and EN 60079-10-2			
of compliance with the EHSRs is valid as there are no changes which materially affect the state of technological progress of the product.			
en conformité avec les EESS est valide puisqu'il n'y a aucun changement qui affecte matériellement l'état de l'évolution technologique du produit.			
zur Erfüllung der GSGA ist gegeben, da keine Änderungen erfolgt sind, die einen Einfluss auf den technischen Stand des Produkts haben.			
Terms of the directive:		Standard & Date Certified to	Standards Date Declared to
Prescription de la directive:		Standard & date certifiée à	Normes date Déclaré
Bestimmungen der Richtlinie:		Standard & Datum Zertifiziert nach	Standards Datum erklärt
2014/34/EU	Equipment and protective systems intended for use in potentially explosive atmospheres.	EN 60079-0 : 2009	2012
		EN 60079-1 : 2007	2014
2014/34/UE	Appareils et les systèmes de protection destinés à être utilisés en atmosphères potentiellement explosibles.	EN 60079-5 : 2007	2015
		EN 60079-7 : 2007	2015
2014/34/EU	Geräte und Schutzsysteme zur bestimmungsgemäßen Verwendung in explosionsfähigen Bereichen.	EN 60079-18 : 2004	2015
		EN 60079-28: 2015	
		EN 61241 : 2004	
		EN 60079-31 : 2014	
2014/30/EU	Electromagnetic compatibility	EN 55015 : 2013	
2014/30/UE	Compatibilité électromagnétique	EN 61547 : 2009	
2014/30/EU	Elektromagnetische Verträglichkeit	EN 61000-3-2 : 2014	
2014/35/EU	Low voltage equipment	EN 60598-1 : 2015	
2014/35/UE	Équipements électriques à bas voltage	EN 60598-2-22 : 2014	
2014/35/EU	Niederspannungsgeräte / -systeme	EN 60529 : 1992	
2012/19/EU	Waste of electrical and electronic equipment	Shell Deluge DTS-01 : 1991	
2012/19/UE	Déchets d'équipements électriques et électroniques	Seismic EN 60068-3-3 : 1993	
2012/19/EU	Entsorgung der elektrischen und elektronischen Geräte / Systeme	Nuclear Seismic IEC 60980-6 : 1993	
2011/65/EU	RoHS II Directive		
Additional information:	The luminaire is capable of withstanding over voltage levels of up to 400V AC for 1 minute and impulse voltage surges of 4kV.		
Informations complémentaires:	Le luminaire peut supporter des niveaux de tensions jusqu'à 400V CA pendant 1 minute et des tensions de choc de 4kV.		



Zusatzinformation :	Dieser Strahler widersteht Überspannungen bis 400V AC 1 Minute lang sowie Stoßspannungen von 4kV.
------------------------	---

On behalf of the Chalmit, I declare that, on the date the equipment accompanied by this declaration is placed on the market, the equipment conforms to all technical and regulatory requirements of the above listed directives.

En tant que représentant du fabricant Chalmit, je déclare qu'à la date où les équipements accompagnant cette déclaration sont mis sur le marché, ceux-ci sont conformes à toutes les dispositions réglementaires et techniques des directives énumérées ci-dessus.

Hiermit bestätige ich, im Namen von Chalmit, dass am Tag der Lieferung des Produkts/der Produkte zusammen mit dieser Erklärung das Gerät/die Geräte alle technischen und regulativen Anforderungen der oben aufgeführten Direktiven erfüllt.

Name and Date	Mark Poutney	31/03/2021	Technical Manager	
Nom et Date			Directeur technique	
Name und Datum			Technischer Leiter	
Quality Assurance Notification by:	SGS Fimko OY	Quality Management System Accreditation:	ISO 9001	
Notification d'assurance qualité par:	0598	Certification du système de gestion de la qualité:	by/par/durch	
Qualitätssicherungsnotifikation durch:		Qualitätsmanagementsystem Akkreditierung:	Lloyd's Register	
		Certificate No./Certificat N°/Zertifikat Nr.	LRQ 4005876	